



JOHN DEERE

6068HF158

POWERTECH

SPECIFICATIONS

For Gen Set Applications

Power Units

TA LUFT approved @ 1500 rpm

EPA - CARB Tier 1 Certified @ 1800 rpm

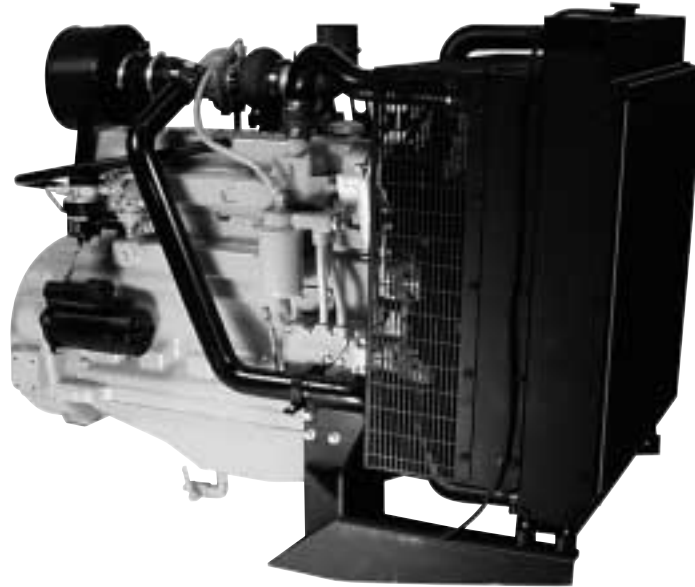

PERFORMANCE DATA

Speed (Hz)	Generator Efficiency %	Fan Power kW	Power Factor	Calculated Gen Set rating					
				Prime			Standby ⁽¹⁾		
				kW net	kVA	kWe	kW net	kVA	kWe
1500 (50)	88-92	5.5	0.8	134	147-154	118-123	148	162-169	130-136
1800 (60)	88-92	9	0.8	161	174-182	139-146	178	195-204	156-163

Note⁽¹⁾: based on nominal engine power

STANDBY POWER

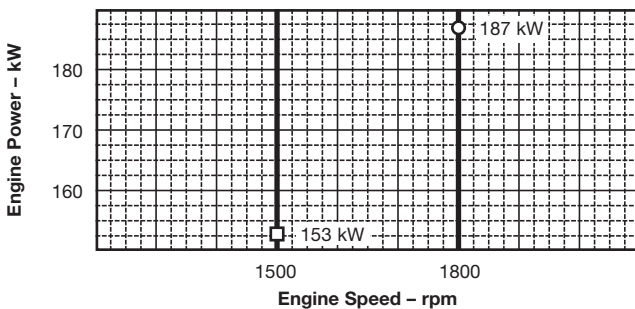

PRIME POWER

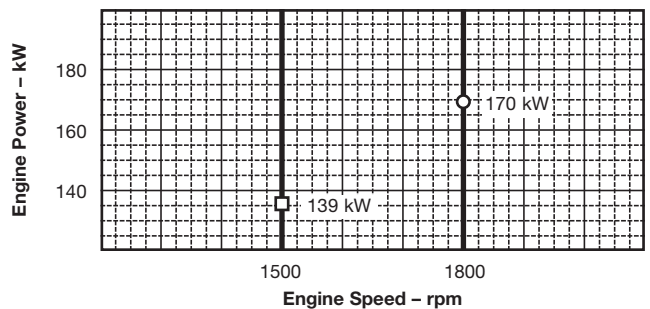

Performance Data	1500 rpm	1800 rpm
Gross Rated Power (without fan)		
Prime = PRP - kW (hp)	139 (186)	170 (228)
Standby = LTP - kW (hp)	153 (205)	187 (251)
Rated Speed - rpm	1500	1800
Low Idle Speed - rpm	No	No
BMEP		
Prime = PRP - kPa (psi)	1635 (237)	1666 (242)
Standby = LTP - kPa (psi)	1800 (261)	1833 (266)
Friction Power @ Rated Speed - kW (hp)	13 (17)	17 (23)
Altitude Capability		
Prime - m (ft)	2300 (7500)	2300 (7500)
Standby - m (ft)	1500 (5000)	1500 (5000)
Air: Fuel Ratio		
Prime = PRP	27.4 : 1	28.6 : 1
Standby = LTP	27.9 : 1	29.0 : 1
Noise		
Prime = PRP - dB(A) @ 1 m	93.6	95.5
Standby = LTP - dB(A) @ 1 m	94.9	96.9

STANDBY POWER is the nominal engine power available at varying load factors for up to 500 hours per year. This rating conforms to ISO 8528-1 "limited time running power (LTP)". The calculated generator set rating range for standby applications is based on minimum engine power (nominal -5%) to provide 100% meet-or-exceed performance for assembled standby generator sets.

PRIME POWER is the nominal power an engine is capable of delivering with a variable load for an unlimited number of hours per year. This rating conforms to ISO 8528-1 "prime power (PRP)".

Photographs may show non standard equipment.



Power Unit Specification Data

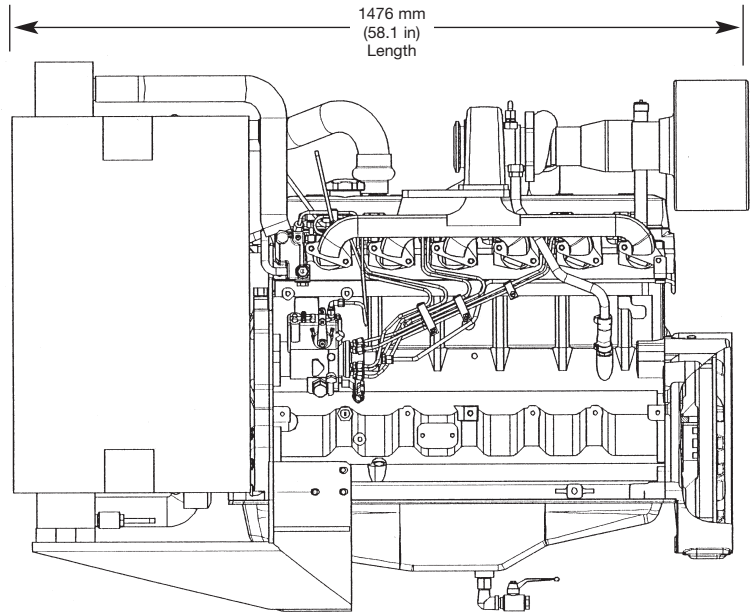
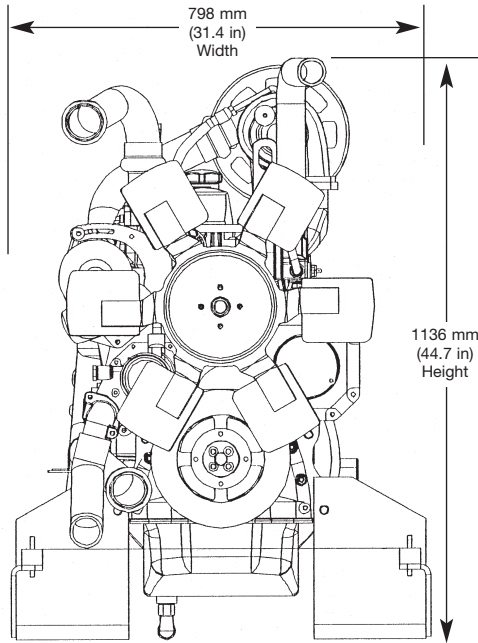

Fuel Consumption – l/h	1500 rpm		1800 rpm	
	Prime = PRP	Standby = LTP	Prime = PRP	Standby = LTP
25% Power	9.3	10.1	11.4	12.5
50% Power	18.0	19.8	21.4	23.9
75% Power	26.6	28.9	32.5	36.2
100% Power	34.4	37.8	42.6	47.0

General Data

Model	6068HF158
Number of cylinders	6
Bore and Stroke – mm (in.)	106 x 127 (4.19 x 5.00)
Displacement – dm ³ (in ³)	6.8 (414)
Compression Ratio	17.0 : 1
Valves per Cylinder – Intake/Exhaust	1 / 1
Firing Order	1-5-3-6-2-4
Combustion System	Direct Injection
Engine type	In-line, 4-cycle
Aspiration	Turbocharged
Charge Air Cooling System	Air to air
Engine Crankcase Vent System	Open
Engine Crankcase Pressure – kPa (in.H ₂ O)	0.5 (2)

Physical Data

Length – mm (in.)	1476 (58.1)
Width – mm (in.)	798 (31.4)
Height – mm (in.)	1136 (44.7)
Weight, dry – kg (lb)	745 (1642)
(Includes flywheel housing, flywheel, & electrics)	
Center of gravity location	
From Rear Face of block (X-axis) – mm (in.)	447 (17.6)
Right of Crankshaft (Y-axis) – mm (in.)	-10 (-0.4)
Above Crankshaft (Z-axis) – mm (in.)	176 (6.9)

Electrical Data

Recommended Battery Capacity (CCA)	
12 Volt System – Amp	800
24 Volt System – Amp	570
Maximum Allowable Starting Circuit Resistance	
12 Volt System – Ohm	0.0012
24 Volt System – Ohm	0.002
Starter Rolling Current – 12 Volt System	
At 0°C (32°F) – Amp	920
At -30°C (-22°F) – Amp	1300
Starter Rolling Current – 24 Volt System	
At 0°C (32°F) – Amp	600
At -30°C (-22°F) – Amp	700

Specifications and design subject to change without notice.

Air System

	1500 rpm	1800 rpm
Maximum Allowable Temperature Rise		
Ambient Air to Engine Inlet – °C (°F)	8 (15)	8 (15)
Maximum Air Intake Restriction		
Dirty Air Cleaner – kPa (in. H ₂ O)	6.25 (25)	6.25 (25)
Clean Air Cleaner – kPa (in. H ₂ O)	3 (12)	3 (12)
Engine Air Flow		
Prime = PRP – m ³ /min (ft ³ /min)	10.2 (360)	12.8 (452)
Standby = LTP – m ³ /min (ft ³ /min)	11.2 (395)	14.1 (498)

Exhaust System

	1500 rpm	1800 rpm
Exhaust Flow		
Prime = PRP – m ³ /min (ft ³ /min)	23.1 (816)	32.0 (1130)
Standby = LTP – m ³ /min (ft ³ /min)	25.4 (897)	37.2 (1243)
Exhaust Temperature		
Prime = PRP – °C (°F)	555 (1031)	533 (991)
Standby = LTP – °C (°F)	575 (1067)	553 (1027)
Max. Allow. Back Pressure – kPa (in.H ₂ O)	7.5 (30)	7.5 (30)
Recommended Exhaust Pipe Dia – mm (in.)	101.6 (4)	101.6 (4)

Cooling System

	1500 rpm	1800 rpm
Thermostat Start to open – °C (°F)	82 (180)	82 (180)
Power Unit Coolant Capacity – L (qt)	26.0 (27.5)	26.0 (27.5)
Minimum Air to Boil temperature – °C (°F)	47 (117)	47 (117)

Fuel System

	1500 rpm	1800 rpm
Fuel Injection Pump	Stanadyne	Stanadyne
Governor Regulation	5%	5%
Governor Type	Mechanical	Mechanical
Total Fuel Flow		
Prime = PRP – kg/h (lb/h)	93 (205)	96 (212)
Standby = LTP – kg/h (lb/h)	93 (205)	96 (212)
Maximum Fuel Transfer Pump Suction – m (ft)	0.9 (3)	0.9 (3)
Fuel Filter Micron Size @ 98% Efficiency	8	8

Lubrication System

	1500 rpm	1800 rpm
Oil Pressure at Rated Speed – kPa (psi)	345 (50)	345 (50)
Oil Pressure at Low Idle – kPa (psi)	105 (15)	105 (15)
In Pan Oil Temperature – °C (°F)	115 (240)	115 (240)
Total Engine Oil Capacity with filter – L (qt)	19 (20.1)	19 (20.1)
Engine Angularity Limits (continuous)		
Any Direction – degrees	20	20



John Deere Power Systems
La Foulonnerie
 Usine de Saran – B.P. 11013
 45401 Fleury les Aubrais Cedex – France

Tel.: (33) 2 38 82 61 19
 Fax: (33) 2 38 84 62 66
 http: www.johndeere.com/engines

